

Power Supply and Voltage Control

AC Power Regulators

APR-D Series (Single-phase)



Single AC power regulators

APR-D series



20A
standard



45A / 60A
control input connector supplied



100A
communication board supplied

RPDE

- Also applicable to control of inductive load and primary control of transformers and rectifiers, through continuous comb tooth pulse control. Optimum for light modulation of LED illumination (for phase control).

Note: When the rated voltage is applied, the load shall flow the minimum load current or more.

- Being able to switch the waveform control method among phase control, cycle control, and phase angle proportion control.

Phase control (0 to 100%)

Output voltage 71%V, $\alpha = 90^\circ$

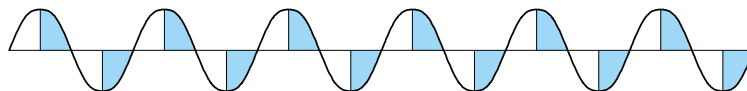

Cycle control (Intermittent control)

Output voltage 71%V, (1/2)

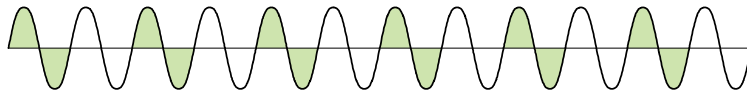

- Space saving is possible due to a class-minimal dense array (minimum interval in width: 2 mm)

Catalog Disclaimer

The information contained in this catalog does not constitute an express or implied warranty of quality, any warranty of merchantability of fitness for a particular purpose is hereby disclaimed.

Since the user's product information, specific use application, and conditions of use are all outside of Fuji Electric FA Components & Systems' control, **it shall be the responsibility of the user to determine the suitability of any of the products mentioned for the user's application.**

One Year Limited Warranty

The products identified in this catalog shall be sold pursuant to the terms and conditions identified in the "Conditions of Sale" issued by Fuji Electric FA with each order confirmation.

Except to the extent otherwise provided for in the Conditions of Sale issued by Fuji Electric FA, Fuji Electric FA warrants that the Fuji Electric FA products identified in this catalog shall be free from significant defects in materials and workmanship provided the product has not been: 1) repaired or altered by others than Fuji Electric FA; 2) subjected to negligence, accident, misuse, or damage by circumstances beyond Fuji Electric FA's control; 3) improperly operated, maintained or stored; or 4) used in other than normal use or service. This warranty shall apply only to defects appearing within one (1) year from the date of shipment by Fuji Electric FA, and in such case, only if such defects are reported to Fuji Electric FA within thirty (30) days of discovery by purchaser. Such notice should be submitted in writing to Fuji Electric FA at 5-7, Nihonbashi Odemma-cho, Chuo-ku, Tokyo, Japan. The sole and exclusive remedy with respect to the above warranty whether such claim is based on warranty, contract, negligence, strict liability or any other theory, is limited to the repair or replacement of such product or, at Fuji Electric FA's option reimbursement by Fuji Electric FA of the purchase price paid to Fuji Electric FA for the particular product. **Fuji Electric FA does not make any other representations or warranties, whether oral or in writing, expressed or implied, including but not limited to any warranty regarding merchantability or fitness for a particular purpose.** Except as provided in the Conditions of Sale, no agent or representative of Fuji Electric FA is authorized to modify the terms of this warranty in writing or orally.

In no event shall Fuji Electric FA be liable for special, indirect or consequential damages, including but not limited to, loss of use of the product, other equipment, plant and power system which is installed with the product, loss of profits or revenues, cost of capital, or claims against the purchaser or user of the product by its customers resulting from the use of information, recommendations and descriptions contained herein. The purchaser agrees to pass on to its customers and users, in writing at the time inquiries and orders are received by buyer, Fuji Electric FA's warranty as set forth above.

AC Power Regulators APR-D Series (Single-phase)

	Page
Features	2
Type number nomenclature	3
Types and ratings	3
Specifications	4
Wiring diagram	5
Other options	6
Dimensions.....	9

AC Power Regulators APR-D series

Single AC power regulators APR-D series

■ Description

The single-phase APR-D series of products are successors of αB and αC.

Whereas their functions and performance have been largely improved due to incorporation of a CPU, space saving, less wiring, and inexpensive cost have been achieved.

■ Features

- Also applicable to control of inductive load and primary control of transformers and rectifiers, through continuous comb tooth pulse control.

Optimum for light modulation of LED illumination (for phase control).

Note: When the rated voltage is applied, the load shall flow the minimum load current or more.

- Being able to switch the waveform control method among phase control, cycle control, and phase angle proportion control.

Phase control (0 to 100%)

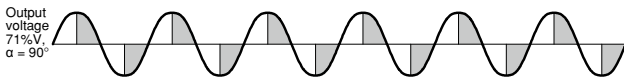

Cycle control (Intermittent control)

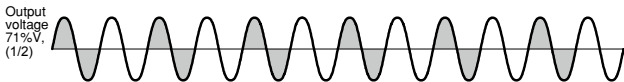

- The standard configuration does not include a control input connector. (Less wiring, low cost)
For auto setting or manual setting only, it is possible to adjust the device by changing the function of the control input terminal block.

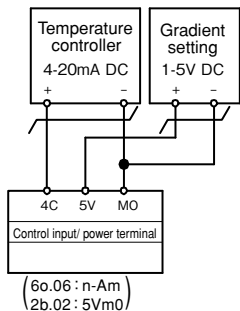
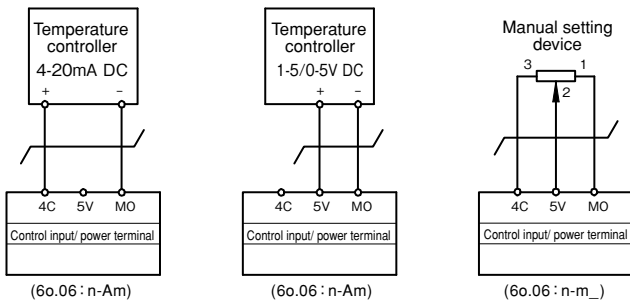

Note: The factory defaults are n-Am for 6o.06 and Aod for 2b.02.
The parentheses show function codes and terminal functions.

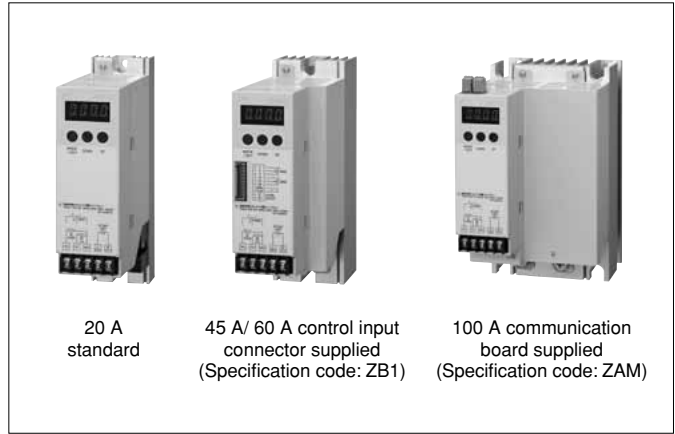

- Space saving is possible due to a class-minimal dense array (minimum interval in width: 2 mm)
- Base load setting, digital settings including gradient setting, and monitor functions are available as part of the standard configuration.

Operation example

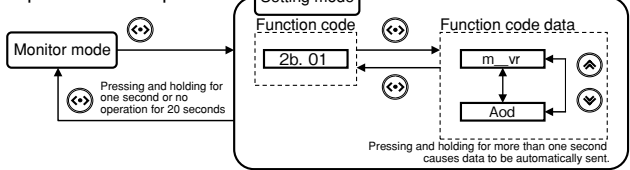

- Allows soft start time, soft up time, and soft down time to be discretely set in the range of 0 seconds to 100.0 seconds.
- Performs auto identification of 100 to 240 V AC and 50/60 Hz with respect to control power
- As a control method, current limit control and automatic current feedback control are available.
You can also detect heater disconnection (cycle control: load opening).

Note: It is possible to detect disconnection of one to three lines in an alloy heater where there are small changes in resistance depending on the temperature.

- Allows communication control as an optional function.
Option type of the main unit:
ZAP: Up to 50 units can be operated in parallel.
For cycle control, a flicker prevention function is available.

ZAM: Various settings and monitors are possible by means of RS485 (Modbus RTU).

- All models satisfy CE marking.



■ Type number nomenclature

RPD E 2 0 6 0 - T 1 - Z B 1 (Note 1)

Product category

Product	Code
APR-D series	RPD

Number of phases

Number of phases	Code
Single phase	E

Input voltage

Input voltage	Code
100-240V	2

Rated current

Rated current	Code
20A	020
45A	045
60A	060
100A	100

Specifications

Specifications	Code
Standard	Blank
Option of the main unit	Z** (Note 3)

Setting device (Note 2)

Setting device	Code
Non	Blank
Setting device: 1 set	1
Setting device: 2 sets	2
Setting device: 3 sets	3

Control method

Control method	Code
No feedback function	T
AC CLR	A
AC ACR plus AC CLR	B

CLR: Current limit regulator
ACR: Automatic current regulator

Note 1: For the order codes which are blank, put no space, immediately followed by a hyphen.

Note 2: One set of setting devices is composed of a variable resistor, nameplate, control knob, and attachment sheet. The format of a separate order is "RPD001". This is not shown as the type of the main unit.

Note 3: For options of the main unit, it is possible to specify multiple specification items like RPDE2020-T1-ZAMB1.

Option specification names	Description	Type
Communication board (For parallel run)	Mounting a communication board for parallel run, equipped with a flicker prevention function (Note 4)	RPDE2□□□-□-■-ZAP
Communication board (For network connections)	Mounting a communication board for Modbus RTU	RPDE2□□□-□-■-ZAM
Control input connector	A connector is supplied to support functions including manual, gradient setting input (external attachment) and alarm output. (Note 5)	RPDE2□□□-□-■-ZB1
Main-circuit power On soft start	Soft start through main-circuit power On is possible. (Pure metal load can be handled.) (Note 6)	RPDE2□□□-□-■-Z45

Note 4: The parallel run function provided by this communication board is not compatible with models other than the APR-D series.

Note 5: A connector set (socket: built-in/ plug: supplied) for a European terminal block is supplied to support manual, gradient setting input (external variable resistor), auto/manual switching input, and alarm input. If the plug is not needed, specify ZB0.

Note 6: When the APR is to be connected with the secondary side of a transformer, this option type is not applicable.

Note 7: Note that options of the main unit are attached before shipment.

■ Types and ratings

Number of phases	Input voltage	Output current (A)	Type
Single phase	Common for 100 to 240 V	20	RPDE2020-T
			RPDE2020-A
		45	RPDE2045-T
			RPDE2045-A
		60	RPDE2060-T
			RPDE2060-A
100	RPDE2100-T		
	RPDE2100-A		

Note: The price does not include a setting device and the main unit's options.
The price of control method B type is the same as of control method A type.

■ Important notes in selecting product

• Allowed load current/ ambient temperature characteristics

The standard rated current value is the one at an ambient temperature of 40°C. When it exceeds 40°C, reduce the load current as below:

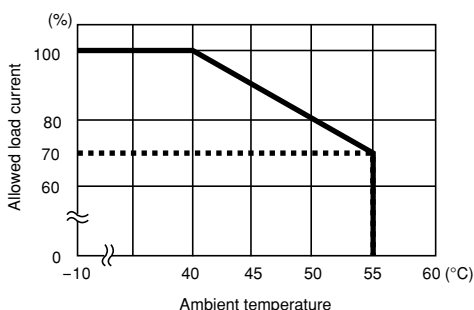

• Options of the main unit

After delivery, addition and alternation are not allowed for the type (product code). Please remember this when making an order.

• Rapid fuse

The main circuit does not contain a fuse. Use a rapid fuse depending on the capacity.

• Selection of rated current

Considering that a large inrush current flows in an incandescent lamp or pure metal heater (a current that is several to ten times larger than a steady-state current for approx. 1/20 seconds to several seconds), choose the rated current very carefully.

• Primary control of a transformer (primary control of a rectifier)

- (1) If the transformer may be subject to no load, resistor attachment is needed to cause 0.5 A to flow in the primary wiring in parallel.
- (2) So that bias magnetism is well prevented, extra magnetic flux density shall be considered. (1.0 to 1.2 T)
- (3) Even if the line voltage becomes below -15%, output of APR-D is kept. Recovery of the line voltage may result in overcurrent caused by bias magnetism phenomenon.

• Important notes for power cycle life expectancy

If run and stop are repeated at short-period cycles (for example, 30-minute run and 30-minute stop), a large difference in temperature occurs in the thyristor element, significantly shorting its life expectancy through thermal fatigue. If such operations need to be performed, try to minimize the temperature fluctuation. Specifically, reduce the use rate of rated current to less than 80%. Or, choose an APR whose rated current is one level higher, so that the use rate of rated current is less than 80%.

AC Power Regulators

APR-D series

■ Specifications

Item		Specifications				
Type		RPDE2020-□	RPDE2045-□	RPDE2060-□	RPDE2100-□	
Input	Main circuit/ control circuit	Rated input voltage and frequency	Single phase 100/240 V AC 50 Hz/ 60 Hz (Auto identification)			
		Input voltage range	Rated input voltage $\pm 10\%$ (Performance guarantee) (Note 1) Rated input voltage $\pm 15\%$ (Operation guarantee)			
		Input frequency range	50Hz/60Hz ± 2.5 Hz			
	Control circuit	Input capacity	15 VA or less			
Output	Rated current (Ambient temperature: 40°C)	20	45	60	100	
	Cooling system	Self-cooled				
	Applied load	Resistive load, inductive load, primary control of a transformer, primary control of a rectifier (For cycle control, resistive load (alloy) only)				
	Minimum load current	0.5 A (With 100% output of the rated input voltage)				
	Generation loss (with rated current) [W]	30	55	70	110	
Control	Waveform control method		Single-phase thyristor normal/reverse parallel connection Phase control/ cycle control (intermittent)/ phase angle proportion control			
	Output voltage adjustment range		0 to 100% (RMS value) of the main-circuit line voltage (thyristor voltage drop portion excluded)			
	Input/output characteristics		Linear characteristic of RMS value/ linearity: $\pm 3\%$ FS or less (phase control) Linearity: $\pm 5\%$ FS or less (cycle control) (With resistive load/ setting signal 10% to 90%)			
	Setting signal	Auto setting	Current signal: 4 to 20 mA DC ($Z_{in} = 100 \Omega$) Voltage signal: 0 to 5 V DC, 1 to 5 V DC ($Z_{in} = 11 \text{ k}\Omega$) SSC signal: 0 V/ 12 V DC ($Z_{in} = 11 \text{ k}\Omega$)			
		Manual setting	External variable resistor: 1 k Ω (B characteristics 1/2 W or more)			
		Digital setting	Front key input (Possible direct drive)			
		High/low setting (2-position control)	Possible combinations by means of digital setting and an external variable resistor External contact switching by means of digital setting or control input connector (option of the main unit), with respect to contact switching signals			
	Gradient setting	Setting range	0 to 100% of output voltage			
		Setting equipment	Voltage signal setting through digital setting (1 to 5 V DC only), external variable resistor (1 k Ω), or control circuit terminal (5 V, M0) Possible countergradient characteristics through combinations with base load setting			
	Base load setting	Setting range	0 to 100% of output voltage			
		Setting equipment	Digital setting			
	Soft start time	Setting range	Control method T type, A type: 0 to 100 seconds			
	Soft up time		Control method B type: 0.5 to 100 seconds (Note 2)			
	Soft down time		Digital setting Discrete setting is possible for each time.			
Feedback control method (Phase control only)		AC CLR (Control method A type) AC ACR plus AC CLR (Control method B type) (Prioritized run of AC CLR)				
Manual/auto Switching signal		Non-voltage contact				
Communication (Note 4)	Parallel run Master/slave		Maximum number of connectable units: 50 Main unit's option type "ZAP" (Not compatible with the APR-N series)			
	Network communication		RS-485 conformed Two-wire system Half duplex start-stop synchronization Protocol: Modbus RTU conformed Maximum number of connectable units: 31 Main unit's option type "ZAM"			
Fault detection/ protection	CPU memory error		CPU memory error detection at the time of initiation			
	Power failure		Detection of control power frequency outside the range from 45 to 65 Hz			
	Auto setting input, not connected		Detection of non-connection of current signal (4 to 20 mA DC) and voltage signal (1 to 5 V DC) (Only with auto setting)			
	Manual setting input, not connected		Detection of non-connection of a manual setting device (external variable resistor) (Only with manual setting)			
	Gradient setting input, not connected		Detection of non-connection of an gradient setting device (external variable resistor or 1 to 5 V DC)			
	Reverse phase detection		Detection when the main-circuit power phase and control power phase are reverse (Main unit's option type "Z45" only)			
	Data writing/reading error		Detection of read/write errors from/to EEPROM			
	Thyristor failure		Detection of thyristor shorting through built-in CT (Control method A type, B type)			
	Communication failure		Detection of data transmission failure (main unit's option type "ZAP" or "ZAM") at the time of parallel run or network communications			
	Current limit detection		Detection of load current exceeding the CLR setting value; decrease of the current to the CLR setting value (or lower) through phase angle change (Control method A type, B type)			
	Heater disconnection		Detection of APR output current values lower than the disconnection judgment value (Control method A type, B type) (Note 3)			
	Alarm output		Open collector 24 V DC/ 0.1 A 1 circuit			
	Operational environment	Ambient temperature		-10 to +55°C (If the temperature is over +40°C but within +55°C, the load current is to be reduced to the rated current value.)		
Storage temperature		-20 to +60°C				
Ambient humidity		+5 to +95%Rh (There must be no condensation.)				
Others		There must be no factor, action, and vibration which induce corrosive gas, fine particles, and insulation deterioration. Indoor, 1000 m or less altitude				
Insulation	Dielectric strength (Between the main circuit and the earth)		2000 V AC, 1 minute			
	Insulation resistance (with the earth)		10 M Ω or more with 500 V DC megger			

Note 1: Performance guarantee designates satisfying specifications and assuring proper run of the product. Operation guarantee designates assurance of damage-free parts and proper run of the product.

Note 2: Soft start and soft up/down time regarding control method B type are invalid even if set to a time which is shorter than the response speed in terms of PI control. This is because PI control is prioritized over soft start and soft up/down time.

Note 3: For cycle control, load open detection is performed.

Note 4: Only any one type of communication board can be mounted before shipment.

■ Wiring diagram

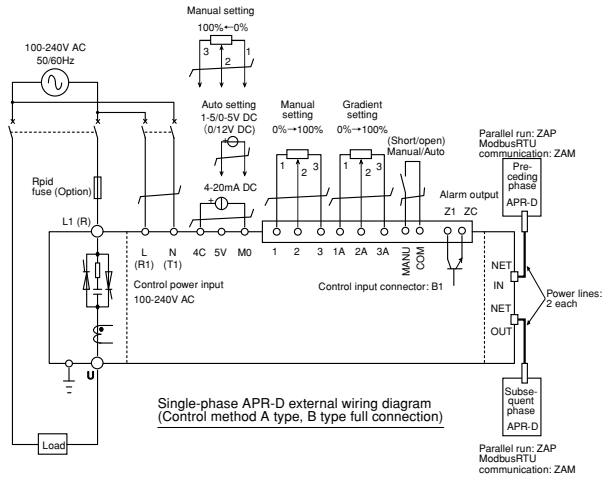

• Wiring of the main-circuit terminals and control power terminals

(1) When the main-circuit voltage is 100 to 240 V AC

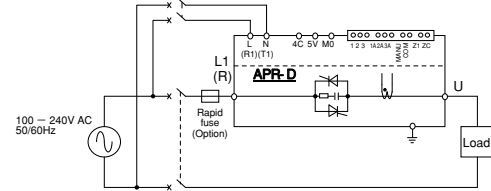

(2) When the main-circuit voltage is not 100 to 240 V AC

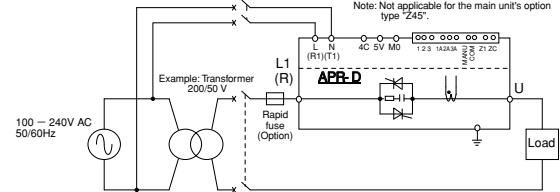

• Positions and functions of connection terminals

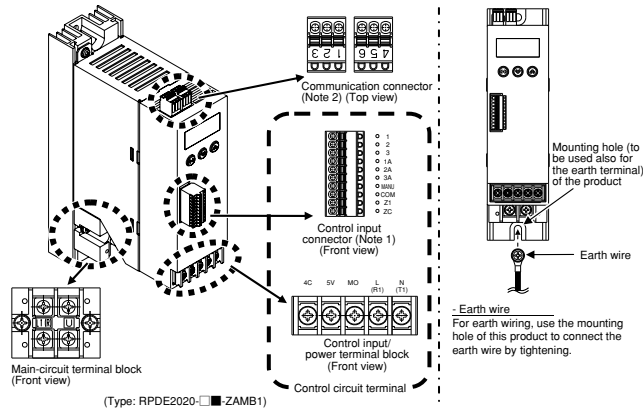

Note 1: To be supplied when the main unit's option "ZB1" is specified.
Note 2: To be supplied when the main unit's option "ZAM" is specified.

• Screw size and tightening torque

Terminal		Screw size	Tightening torque [N·m]±10%
Main-circuit terminal block	L1 (R) , U	20A M4	1.8 (18kgf·cm)
		45A M5	2.7 (27kgf·cm)
		60A M5	
	100A M8	12.0 (120kgf·cm)	
Control input / power terminal block	L (R1) , N (T1) , 4C, 5V, M0	M3	0.5 (5kgf·cm)
Control input connector	1 to ZC	—	—
Communication connector	NET IN, NET OUT	—	—
Main-unit mounting screw (To be used also for the earth terminal)		20-60A M5	3.5 (35kgf·cm)
		100A M6	5.8 (58kgf·cm)

• Terminal function

Terminal type	Terminal position	Pin	Symbol	Name	Function description
Main-circuit terminal block		—	L1 (R)	Main-circuit terminal	L1 (R): Main-circuit power input
		—	U		U: APR output (Connection to load)
		—	—	Earth terminal	Main unit's earth terminal (Shared mounting hole)
Control circuit terminal	Control input/power terminal block	—	4C (3)	Auto setting input (Function code 60.06 = n-Am (factory default))	4C - M0: 4 to 20 mA DC input (Zin = 100 Ω) 5V - M0: 1 to 5 V DC 0 to 5 V (SSC signal: 0/12 V) (Zin = 11 kΩ) It is possible to allocate 5V - M0 to 1 to 5 V DC gradient setting input.
		—	5V (2)		
		—	M0 (1)	Manual setting input (Function code 60.06 = n-m_)	Connecting a variable resistor makes it possible to use as manual setting input. * When using this terminal as manual setting input, detection of manual setting non-connection is not performed.
		—	L (R1)	Control power terminal	Control power input. Input the same phase as that of the main circuit.
		—	N (T1)		
	Control input connector (option)	1	1	Manual setting input	Connecting a variable resistor makes it possible to use as manual setting input.
		2	2		
		3	3		
		4	1A	Gradient setting input	Connecting a variable resistor makes it possible to use as gradient setting input.
		5	2A		
Communication connector (Option)	Network	1, 2	NET IN	RS-485 input/output	When in network communications (option type: ZAM), various kinds of data are sent to and received from a host using the ModbusRTU protocol.
		4, 5	NET OUT		
	Parallel run	1, 2	NET IN	Parallel run input	When in parallel run (option type: ZAP), parallel run signals are received from the preceding APR.
		4, 5	NET OUT	Parallel run output	When in parallel run (option type: ZAP), parallel run signals are sent to the subsequent-phase APR.

AC Power Regulators

APR-D series

■ Other options

- Replacement adapter for APR-αB and αC (RPD002-E □□)

Type	Description
RPD002-E02	For RPDE2020-□
RPD002-E06	For RPDE2045-□, RPDE2060-□
RPD002-E10	For RPDE2100-□

Note: Attach the adapter to the mounting holes (for APR-α B and α C) on the board, and then attach the APR-D to the adapter. For RPCE2020-□, RPD002-E06 shall be applied.

- Control input connector (Plug side), DIN rail-mounting adapter

Type	Description
RPD003	Control input connector (plug for ZB0)
RPD004-E02	DIN rail-mounting adapter for RPDE2020-□

- Rapid fuse

Rated current (APR type)	Rapid fuse (Rated current)	Rapid fuse holder	Base and cap
20A (RPDE2020)	CR2LS-30 (30 A) or BLC045-1 (45A)	CM-1A	AFa60+Pa60 (for BLC)
45A (RPDE2045)	CR2LS-75 (75A) or BLC075-1 (75A)	CM-1A (For CR2LS; tripolar product)	AFa100+Pa100 (for BLC)
60A (RPDE2060)	CR2LS-100 (100A) or BLC090-1 (90A)		
100A (RPDE2100)	CR2L-150 (150A)	CM-2A (Tripolar product)	–

■ The standard configuration of the APR-D series contains display/operation sections for various monitors and settings.

• Names and functions of the individual parts

Name	Function	Name	Function
Drive monitor	Data display section 4th digit DP Run output Presence (lighting up)/ absence (going off)	UP key DOWN key	Use, for example, to select run information shown on the data display section and to change the function code data. * Press and hold for one second or longer to perform auto switch of the data display.
Data display	4-digit 7-segment LED monitor The information below is shown depending on operation modes. • When in monitor mode Run information (Output instruction value, output current, input current, etc.) When an alarm is generated, an alarm code is shown. The 4th digit shows items regarding various pieces of run information. • When in setting mode Information such as a function code and function code data is shown.	MODE/ SET key	Use to switch the operation mode. • When in monitor mode Press and release to switch to the setting mode. • When selecting a function code in the setting mode Press and release to switch to function code data display. Press and hold for 1 second or longer to switch to the monitor mode. • When setting function code data in the setting mode Press and release to confirm data. Press and hold for 1 second or longer to cancel the setting and return to the monitor mode.
Alarm indicator	Data display section 1st digit DP Alarm Presence (blinking)/ absence (going off)		

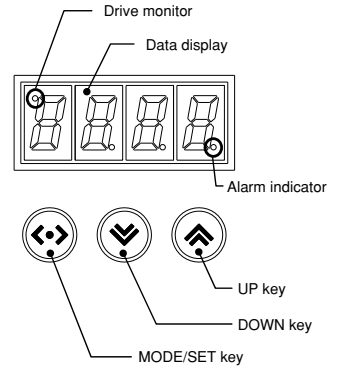

• Monitor mode

Operating the UP and DOWN keys causes the monitor items below to be shown.

(The alarm code is shown only when a failure occurs.)

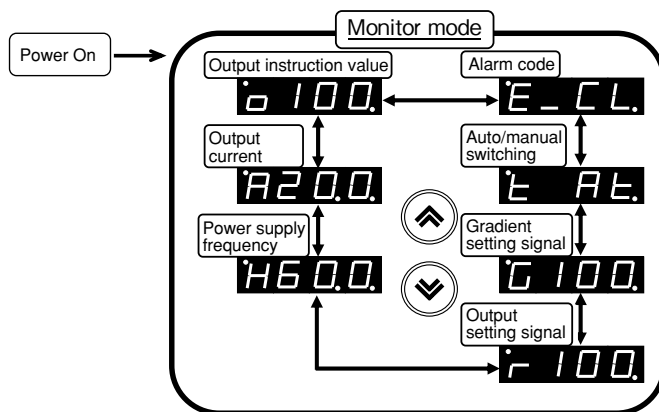

	Monitor item	Function item display	Display	Unit	Display description	Monitor accuracy (Note)	
						T	A/B
1	Output instruction value	o	100	%	Output instruction through APR internal calculation	○	
2	Output current	A	20	A	AC output current detection value	—	○
3	Power supply frequency	H	60.0	Hz	Power supply frequency detection value	○	
4	Output setting signal	r	100	%	Setting signal detection value	○	
5	Gradient setting signal	G	100	%	Gradient setting signal detection value	○	
6	Auto/manual switching	t	At/mn	—	Auto/manual switching terminal status indication	—	
7	Alarm code	E	_SM	—	Indication at the time of alarm generation	—	

Note: Monitor accuracy: ○=5%

• Setting mode

It is possible to set and confirm the data below, for each item:

Category	Display	Setting item	Description of the main functions
Data setting	1b.__	Basic function 1 b code (1b.01 to 1b.06)	Setting to be used for basic APR operations Mainly substitute of external volume
	2b.__	Basic function 2 b code (2b.01 to 2b.07)	Setting to be used for basic APR operations Mainly function selection
	3F.__	Feedback function F code (3F.01 to 3F.08)	Setting relating to feedback CLR setting, heater disconnection function
	4n.__	Network function n code (4n.01 to 4n.08)	Communication relating setting
	5A.__	Alarm function A code (5A.01 to 5A.09)	Alarm output (control input connector) setting
Setting option	6o.__	Setting option function o code (6o.01 to 6o.07)	Utility function setting (For example, display of function codes changed from factory defaults and restriction of operations of the setting display section)
Initial setting	0i.__	Initial setting function i code (0i.01 to 0i.05)	Type setting, ROM version confirmation

AC Power Regulators APR-D series

• Example of setting groups

Function code	Name	Function code data (Settable range)	Step size	Unit	Factory default
1b.01	Manual digital setting	0 to 100.0(%)	0.1	%	0
1b.02	Gradient digital setting	0 to 200.0(%)	0.1	%	100.0
1b.03	Base load setting	0 to 100.0(%)	0.1	%	0
1b.04	Soft start time setting	T type, A type: 0 to 100.0 (seconds)	0.1	seconds	0.5
1b.05	Soft up time setting	B type: 0.5 to 100.0 (seconds)	0.1	seconds	0.5
1b.06	Soft down time setting		0.1	seconds	0.5

• Gradient setting/ base load setting

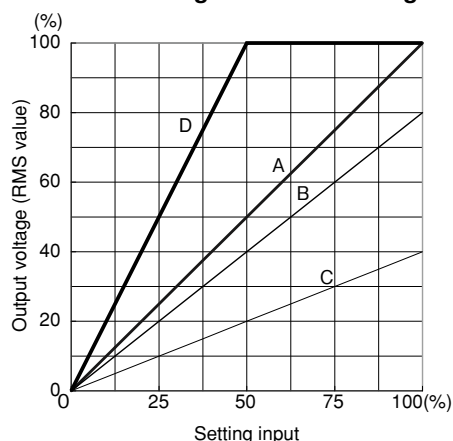

Characteristics	Output adjustment range (%)	Base load setting (%)	Gradient setting (%)
A	0 to 100	0	100
B	0 to 80	0	80
C	0 to 40	0	40
D	0 to 100	0	200

Gradient setting: Set an output value to be presented when setting input is 100%. (Setting range: 0 to 200%)
Note: The upper limit output value is 100% of input voltage.

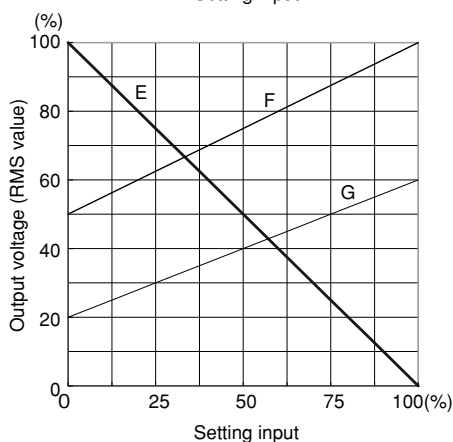

Characteristics	Output adjustment range (%)	Base load setting (%)	Gradient setting (%)
E	100 to 0	100	0
F	50 to 100	50	100
G	20 to 60	20	60

Base load: Set an output value to be presented when setting input is 0%. (Setting range: 0 to 100%)
Actual output represents characteristics resulted from the connection between a base load setting value and gradient setting value using a straight line.

• Heater disconnection detection (Control method A type, B type)

Heater disconnection is recognized when the load current becomes lower than the current value which has been set with the heater disconnection judgment level.

- Applied heater: Alloy heater (Load which flows 40 to 100% of the rated current when the output voltage is 100%)
- Number of parallel lines: 1 to 3 (The material and capacity must be identical.)
- For phase control/ phase angle proportion control
When setting 5% or higher: Disconnection is detected when the output current is 5 (approx.) to 100% of the rated current.
- Cycle control
When setting less than 5%: Invalid disconnection judgment
When setting 5% or higher: Load open is detected when the output current is less than 5% (approx.) of the rated current.
- Judgment range: 30 to 100% of the output instruction value
- Judgment accuracy: $\pm 5\%$ FS or less

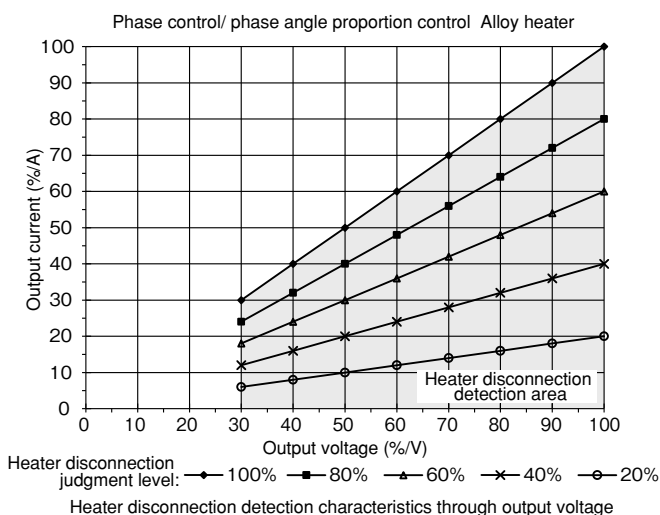

AC Power Regulators
APR-D series

■ MEMO

Safety Considerations

- Operate (keep) in the environment specified in the operating instructions and manual. High temperature, high humidity, condensation, dust, corrosive gases, oil, organic solvents, excessive vibration or shock might cause electric shock, fire, erratic operation or failure.
- For safe operation, before using the product read the instruction manual or user manual that comes with the product carefully or consult the Fuji sales representative from which you purchased the product.
- Products introduced in this catalog have not been designed or manufactured for such applications in a system or equipment that will affect human bodies or lives.
- Customers, who want to use the products introduced in this catalog for special systems or devices such as for atomic-energy control, aerospace use, medical use, passenger vehicle, and traffic control, are requested to consult with Fuji Electric FA.
- Customers are requested to prepare safety measures when they apply the products introduced in this catalog to such systems or facilities that will affect human lives or cause severe damage to property if the products become faulty.
- For safe operation, wiring should be conducted only by qualified engineers who have sufficient technical knowledge about electrical work or wiring.
- Follow the regulations of industrial wastes when the product is to be discarded.
- For further questions, please contact your Fuji sales representative or Fuji Electric FA.

 **Fuji Electric FA Components & Systems Co., Ltd.**

5-7, Nihonbashi Odemma-cho, Chuo-ku, Tokyo, 103-0011, Japan

URL <http://www.fujielectric.co.jp/fcs/eng>